

Brushless DC Motors



Merkle-Korff Industries®

A Kinetek Company®

Merkle-Korff offers high efficient Brushless DC Motors that are ideal for commercial food equipment, pump/valve, business equipment/automation, conveyor, pellet stove and medical automation applications.

Merkle-Korff's Brushless DC Motors feature brushless technology, ultra-quiet operation, long life, low RPM/high torque, integrated control, soft start/reversibility and high temperature/high contamination applications.



Features

Internal controller

- Two quadrant programmable control: current limiting, acceleration, speed regulation, and velocity profiles
- Built-in quadrature encoder
- Over-current protection
- Stall condition protection
- 0 – 5 or 0 – 10 VDC speed reference voltage
- Dynamic braking and holding capability
- Input voltage polarity protection
- Electronic commutation

Motor

- Long life
- Ball bearing construction
- 8 pole rotor
- 3 phase stage – wye connection
- High energy/skewed magnets for reduced cogging
- Integral hall sensors for rotor position

Applications

- Commercial food equipment
- Pumps
- Business equipment/automation
- Pellet stove
- Medical/laboratory
- Satellite positioning systems
- Custom solutions

Specifications

- Input voltage: 12 to 32 VDC
- Insulation class: F (155° C)
- Bi-directional
- Speed regulation: open or closed loop, programmable
- Velocity profile: programmable
- Acceleration: programmable
- Temperature protection: 90° C/110° C
- Current limit: programmable
- Tachometer O/P: 2 Ch – 6PPR

Optional features

- Hall only output: externally controlled
- Incremental optical encoder

Merkle-Korff Industries

Headquarters

25 NorthWest Point Blvd
Suite 900

Elk Grove Village, IL 60007

phone: 847.439.3760

fax: 847.439.3963

web: www.merkle-korff.com

U.S. contact: sales@merkle-korff.com

Dimensional diagram

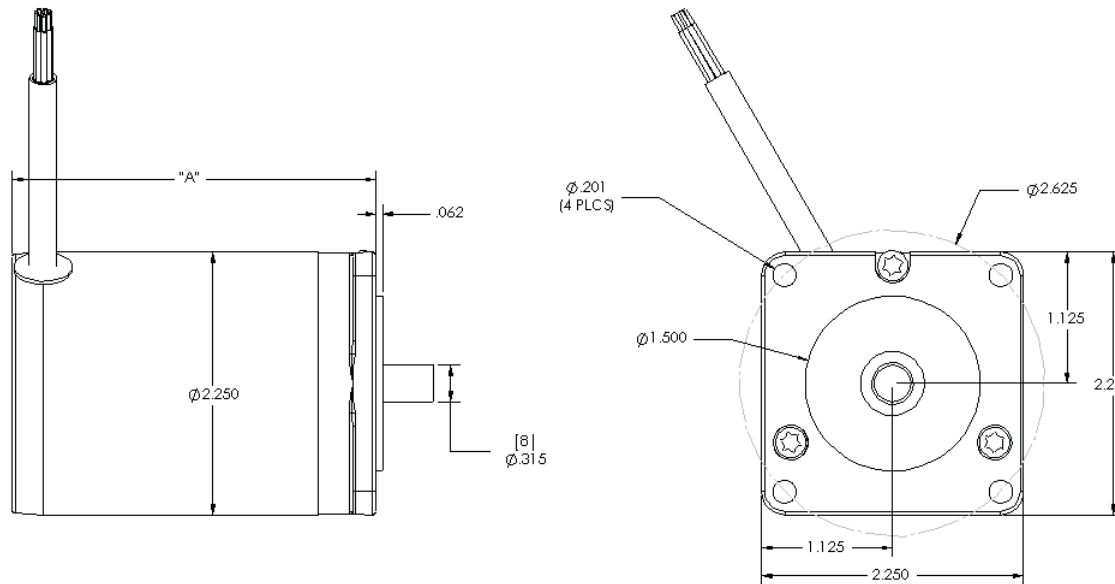

Timing diagram sensor — winding

	Hall-effect sensors			CCW phases			CW phases		
	HA	HB	HC	A	B	C	A	B	C
1	1	0	1	+	-	0	-	+	0
2	1	0	0	0	-	+	0	+	-
3	1	1	0	-	0	+	+	0	-
4	0	1	0	-	+	0	+	-	0
5	0	1	1	0	+	-	0	-	+
6	0	0	1	+	0	-	-	0	+

External (hall only): lead wire color code

Board position	Designation	Lead color
1	motor A	blue
2	motor B	white
3	motor C	brown
4	hall A	green
5	hall B	orange
6	hall C	yellow
7	5UDC	red
8	GND	black

Internal controller: lead wire color code

Board position	Designation	Lead color
1	digital I/O "A"	gray
2	digital I/O "B"	white/red
3	direction	white/black
4	signal ground	green
5	enable input	orange
6	5DVC (output)	yellow
7	input power (12-32VDC)	red
8	power ground	black
9	analog input 2	violet
10	analog input 1 (speed)	blue
11	tach output "B"	brown
12	tach output "A"	white



Merkle-Korff Industries®

A Kinetek Company®

Headquarters

25 NorthWest Point Blvd
Suite 900

Elk Grove Village, IL 60007

phone: 847.439.3760

fax: 847.439.3963

web: www.merkle-korff.com

U.S. contact: sales@merkle-korff.com